

Uniclass L2123 + L7315	EPIC J3413
Cl/SfB (52.5)	

ACO Water Management: Civils + Infrastructure

ACO MultiDrain™
Monoblock PD100D



ACO MultiDrain™ Monoblock PD100D
Monocast channel drainage system



Introduction to the ACO Group

Throughout the world ACO branded drainage and surface water management systems are recognised for their innovative design, high quality manufacture, environmental excellence and industry leading performance.

Today the ACO Group has a research and production base that reaches across four continents. This unmatched resource pioneers the development of solutions that are tailored to individual applications, meeting the need for high performance, sustainable products that deliver optimum value throughout their operational life.

ACO Technologies plc

ACO operates as ACO Technologies plc in the United Kingdom. Founded over 25 years ago, the company has grown quickly on a reputation for design innovation and customer service.

There are 2 core divisions, ACO Water Management and ACO Building Drainage, that serve every sector of the construction industry, providing solutions for applications as diverse as rail, highways, airports, landscaping, retail, distribution centres and environmentally sensitive projects.



To help architects, designers and contractors meet the legal requirements that now tightly control the way surface water is managed, ACO has created its unique 'Surface Water Management Cycle' – Collect, Clean, Hold, Release – the four core processes now required for the complete and sustainable management of surface water drainage.



Contents

Introduction to ACO MultiDrain™ Monoblock PD100D	4
ACO MultiDrain™ Monoblock PD100D system layout	6
ACO MultiDrain™ Monoblock PD100D channel features overview	8
<hr/>	
ACO MultiDrain™ Monoblock PD100D technical data	10
<hr/>	
Designing an ACO MultiDrain™ Monoblock PD100D drainage system	14
Hydraulic performance tables	16
<hr/>	
Preparing the system for installation	18
Installation detail	22
<hr/>	
Material benefits	24
Chemical resistance chart	25
Specification clauses and certification	26



Introduction to ACO MultiDrain™ Monoblock PD100D

The ACO MultiDrain™ Monoblock PD100D one-piece channel system delivers low cost, secure surface water drainage with long lasting aesthetics for a wide range of pedestrian and vehicle applications.

What is ACO MultiDrain™ Monoblock PD100D

ACO Monoblock PD100D is a simple yet versatile channel drainage system for surface water conveyance which has been specifically developed to meet the demands of contractors and clients alike.

Designed to maintain the long term performance and appearance of the installation, its robust one piece construction removes the risks associated with dislodged or stolen gratings – providing a highly effective alternative to traditional two part channel and grating systems.

Manufactured from Vienite®, ACO's high performance recycled material, the system delivers the highest levels of quality, installation and environmental benefits required for modern construction projects, yet has none of the performance compromises associated with other recycled materials on the market.

Specification couldn't be easier as all channels and accessories are certificated to BS EN 1433:2002 load class D 400*, making the system suitable for a range of light duty pedestrian, landscaped and medium duty applications including town centres, commercial developments and parking areas for cars and HGV's.

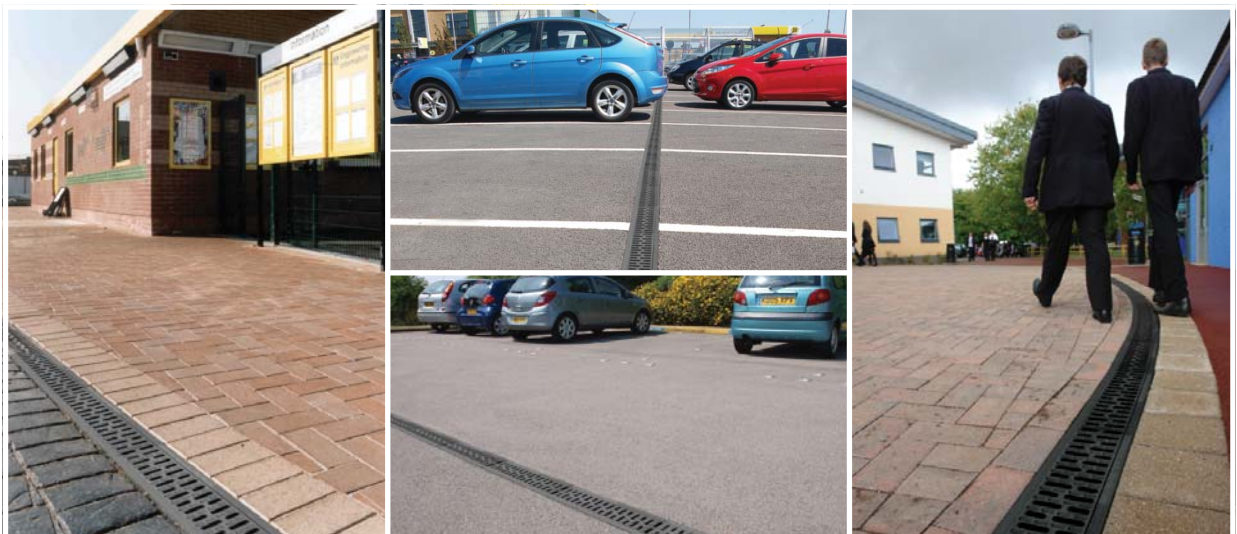

The ACO MultiDrain™ Monoblock PD100D system

The 0.5m channel units form the core of the range and are available in five constant depths. They range in height from 128mm, ideal where installation depths maybe restricted, to the deepest 353mm unit for maximum hydraulic performance.

ACO Monoblock PD100D channels are constructed in one-piece with an integral Heelguard™ grating, making the product incredibly strong and robust, yet light enough to be manually handled with all channel units weighing below 25kg.

The 100mm wide channels are available as standard in Black Vienite® to typically complement asphalt pavements. To provide designers with greater choice, ACO Monoblock PD100D is also available in natural or grey colour options.

Maintenance is provided for by lockable rodding access points, sumps and gully units which allow the system to be simply and efficiently cleaned by standard jetting equipment.

*ACO Monoblock PD100D system is not suitable for carriageways of public roads or motorways - for these applications consider the use of ACO RoadDrain

Why choose ACO MultiDrain™ Monoblock PD100D

Performance and aesthetics

ACO Monoblock PD100D has been designed to assure the longevity and the aesthetics of an installation.

The properties of the material limit the risk of discoloration whilst protecting the long term appearance of the system, and the one piece design removes the hazards and cost associated with dislodged or stolen gratings.

Grey and natural buff colour options are also available to suit aesthetic requirements.

Installation benefits

ACO Monoblock PD100D channel has been designed to improve on site handling and installation rates with each unit 0.5m in length and below 25kg. The lightweight properties of Vienite® and the one piece construction ensures the system is quick and easy to install, even when a fully watertight installation is required.

Made from sustainable materials

All ACO Monoblock PD100D products are manufactured from Vienite®, ACO's high strength recycled material that meets environmental and sustainability targets for construction products.

Four times stronger than traditional concrete, Vienite® utilises high levels of post-consumer recycled waste, but unlike some recycled materials does not compromise strength, long-term performance or the appearance of the system.



- ▶ Safe and secure installation
- ▶ Integral anti-theft grating design
- ▶ Proven performance and durability
- ▶ Manufactured from sustainable material
- ▶ Simplifies specification and design
- ▶ Capacity choices optimise hydraulic performance
- ▶ Many design configurations available including constant depth, step fall, T and L junctions
- ▶ High daily installation rate
- ▶ Maintenance friendly



ACO Hydraulic Design Software

Discover how our free design software allows you to create more effective hydraulic plans.

- ▶ All designs are securely stored and easily accessed online
- ▶ Data always up-to-date
- ▶ Proven calculation methodology - more accurate and efficient designs
- ▶ Flexible catchment design
- ▶ Integrated rainfall data
- ▶ Automated product optimisation
- ▶ PDF summary documents



Register Now - It's Free
www.acodesign.co.uk



ACO MultiDrain™ Monoblock PD100D system layout

The layout diagram below illustrates the channels and components available with the ACO Monoblock PD100D range.

Key

- 1 Inlet/outlet end caps
- 2 ACO Universal gully/silt chamber with ductile iron lockable D 400 grating.
- 3 ACO Monoblock PD100D channels units available in 0.1, 10.1, 20.1 and 30.1 channel sizes

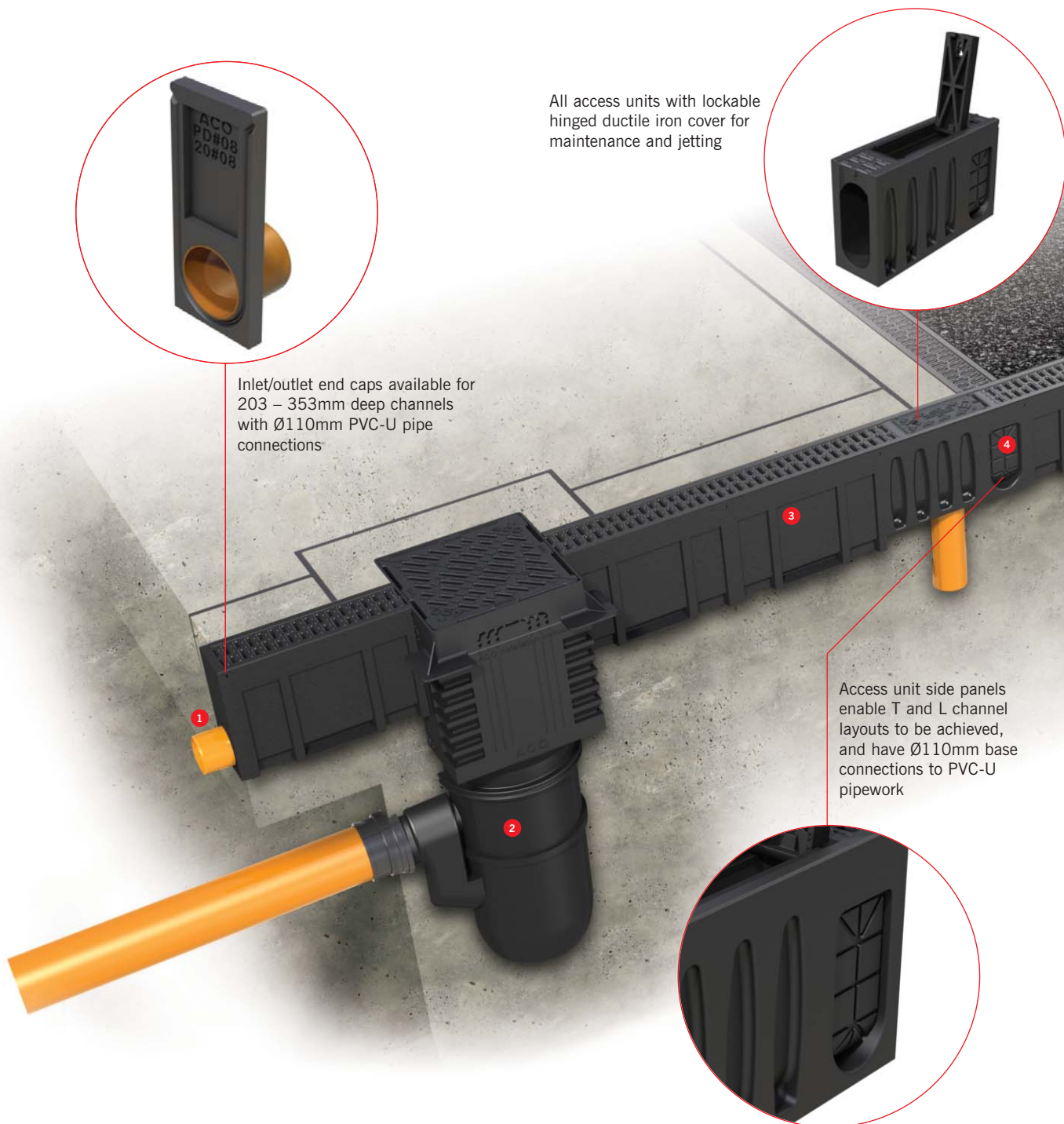

4 ACO Monoblock PD100D access units with lockable ductile iron cover

6 Universal sump with ductile iron Drainlock™ grating

7 Universal closing end cap

5 Step connector



50mm deep channel step connector for smooth water flow and channel connection

Universal sump unit includes silt bucket and connection to Ø110mm and Ø160mm PVC-U pipes and foul air traps

Shallow 128mm deep channel for use where construction depth is restricted

Cut to size universal closing end cap for all channel depths



Guidance for using the ACO Monoblock PD100D parts tables

The ACO Monoblock PD100D parts tables are shown on the following pages. The product information is split down by channels widths and further by channel depth and edge rail type. This is to enable quick and simple product identification and selection.

The tables for ACO Monoblock PD100D (1 or 3) channels list a number associated with the Invert Type. This number highlights the drainage design which can be achieved when using these channels. The key for the Invert Type is shown opposite.

Channel Invert Types

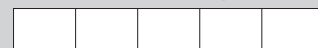

1 Constant Depth Invert



3 Stepped Invert

ACO MULTIDRAIN™ MONOBLOCK PD100D CHANNEL FEATURES OVERVIEW

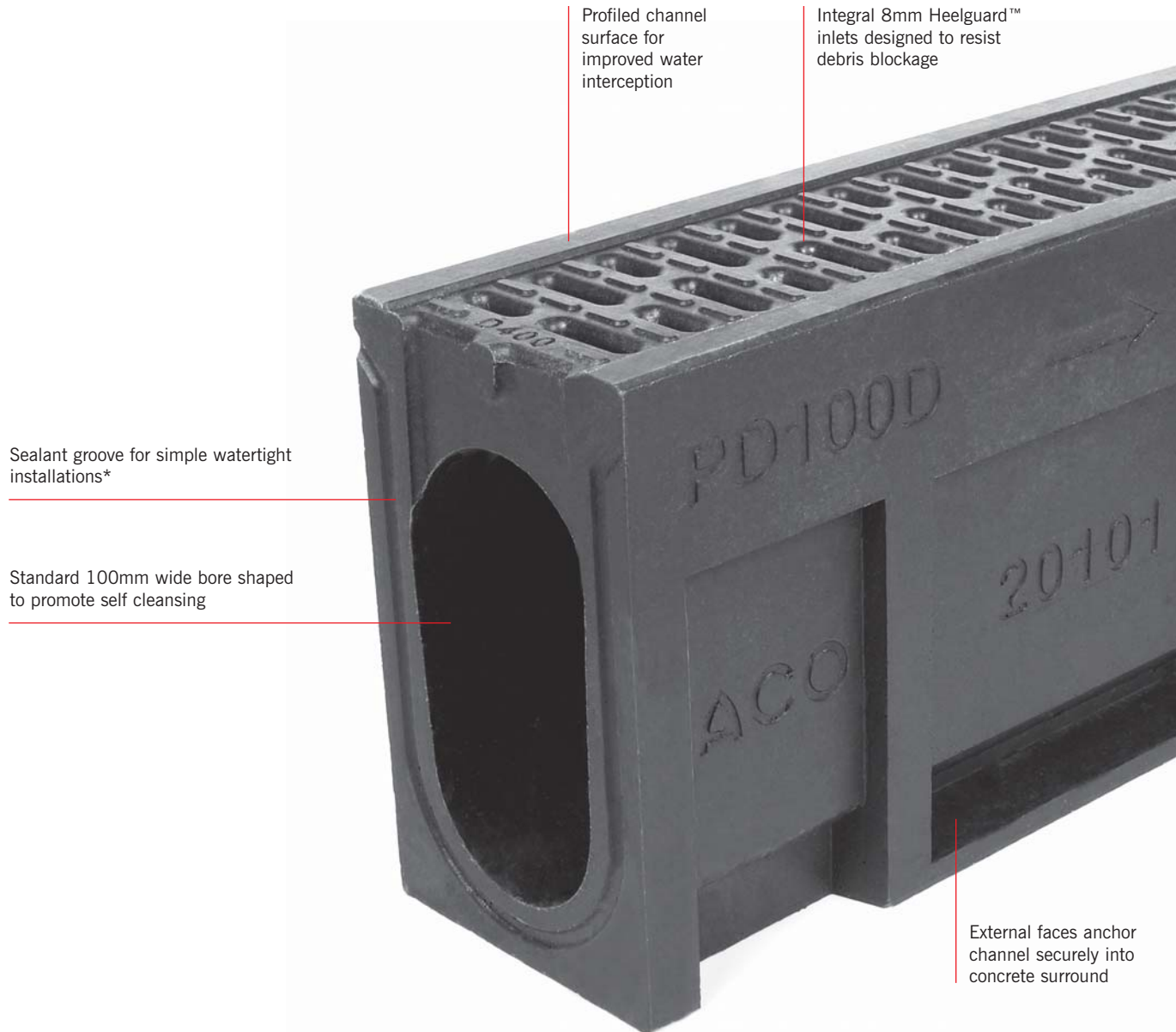

Available channel sizes:

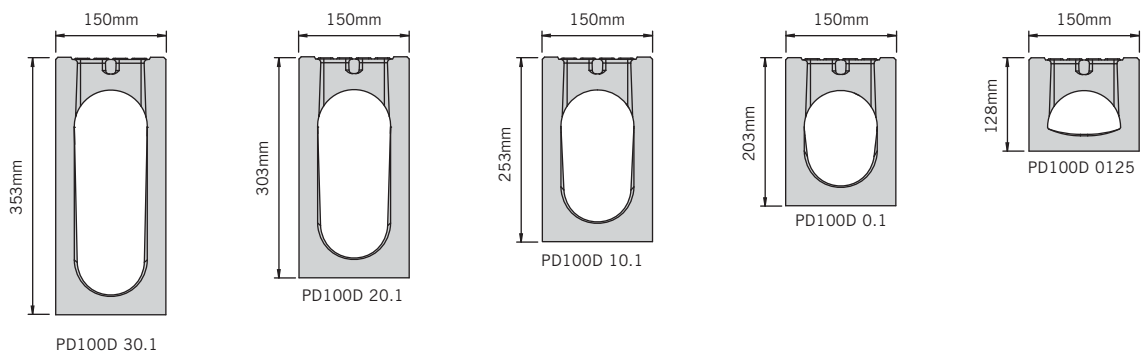

One-piece design for lifetime integrity and security

Less than 25kg channel weight for ease of manual handling

Made from sustainable, robust materials which are thermally stable, chemically resistant and environmental friendly. Manufactured from Vienite®



Colour options

To suit project requirements, ACO Monoblock PD100D is also available in grey and natural buff. For further information about these options please contact our Customer Support Team 01462 816666.

Grey

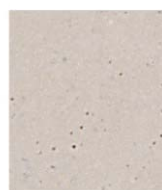

Natural Buff

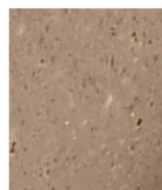

LOAD CLASSES



A 15

Pedestrian, cycleways, minimally trafficked areas (light domestic vehicles only).



B 125

Pedestrian precincts, light vehicles, private car parks and drives.



C 250

Parking areas, service stations (cars) and slow-moving light commercial vehicles.



D 400

Parking areas for all vehicle types†.

† The ACO Monoblock PD100D system is not suitable for carriageways of public roads or motorways.

* ACO Monoblock PD100D channels are tested to confirm compliance with the watertightness requirements of BS EN 1433 when filled with water to the top of the channel bore. See the watertightness note on page 23 for more information.



ACO MultiDrain™ Monoblock PD100D

Constant depth channels and access units (Black±)

Product code	Description	Length (mm)	Width overall (mm)	Depth overall (mm)	Invert depth (mm)	Slot width (mm)	Invert Type	Weight (kg)
20001	PD100D No. 0.1 channel	500	150	203	178	8	1/3	16.3
20003	PD100D No. 0.3J* access	500	150	203	178	-	1/3	22.3
20101	PD100D No. 10.1 channel	500	150	253	228	8	1/3	18.3
20103	PD100D No. 10.3J* access	500	150	253	228	-	1/3	24.6
20201	PD100D No. 20.1 channel	500	150	303	278	8	1/3	20.4
20203	PD100D No. 20.3J* access	500	150	303	278	-	1/3	26.9
20301	PD100D No. 30.1 channel	500	150	353	328	8	1/3	22.4
20303	PD100D No. 30.3J* access	500	150	353	328	-	1/3	29.1

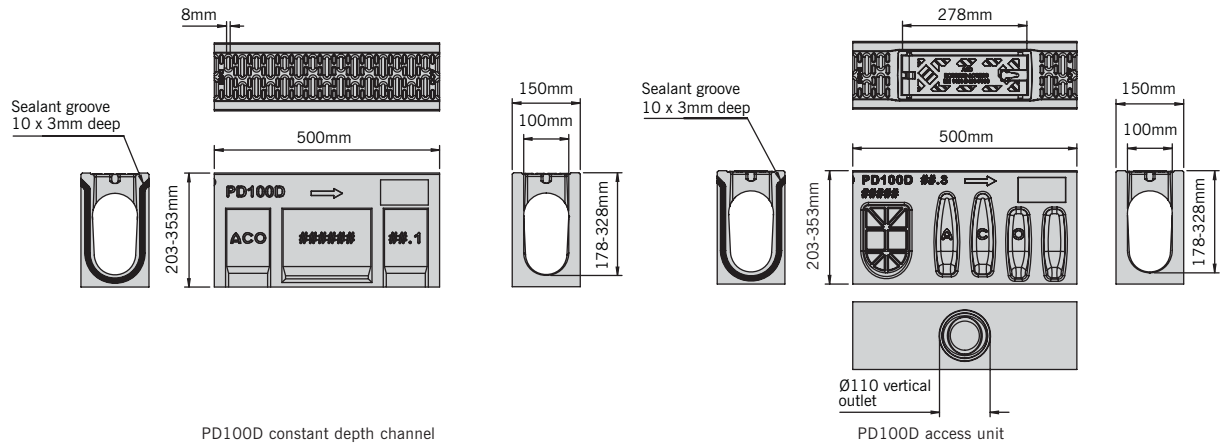

Shallow depth channels and access units (Black±)

Product code	Description	Length (mm)	Width overall (mm)	Depth overall (mm)	Invert depth (mm)	Slot width (mm)	Invert Type	Weight (kg)
20125	PD100D No. 0125 channel	500	150	128	107	8	1	12.2
20123	PD100D No. 0123* access	500	150	128	107	-	1	17.2

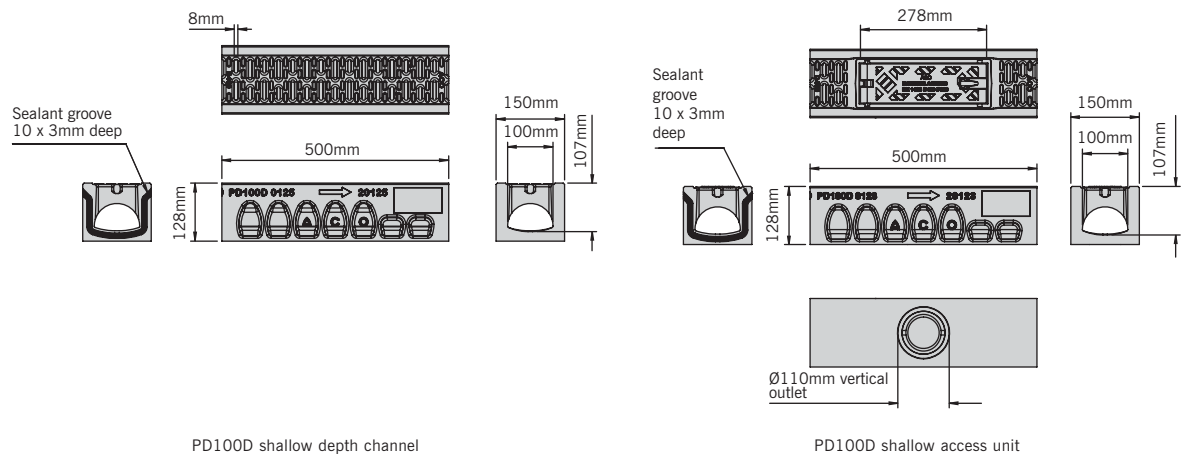

ACO MultiDrain™ Monoblock PD100D

Closing and inlet/outlet end caps, reversible to fit either end of channel (Black±)

Product code	Description	Length (mm)	Width overall (mm)	Depth overall (mm)	Invert depth (mm)	Slot width (mm)	Invert Type	Weight (kg)
20306	PD100D No. 306 closing end cap	25	150	353	-	-	-	2.4
20008	PD100D No. 008 inlet/outlet end cap	25	150	203	178	80	-	1.3
20108	PD100D No. 108 inlet/outlet end cap	25	150	253	228	80	-	1.5
20208	PD100D No. 208 inlet/outlet end cap	25	150	303	278	80	-	1.8
20308	PD100D No. 308 inlet/outlet end cap	25	150	353	328	80	-	2.1

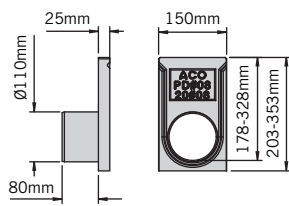

Inlet/outlet end cap

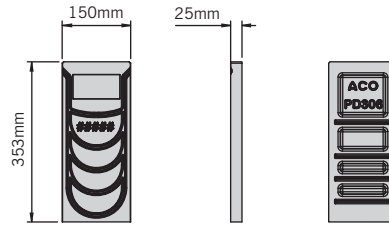

Closing end cap

Step Connector

Product code	Description	Length (mm)	Width overall (mm)	Depth overall (mm)	Invert depth (mm)	Slot width (mm)	Invert Type	Weight (kg)
30123	PD100D No. 123 50mm step connector	115	75	50	-	-	-	0.9

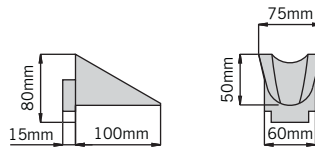

Note. For information on the step connector functionality see page 19.

* Indicates channels supplied with preformed Ø110mm knockout for vertical connection

J Indicates side knockouts for 90° channel connection. Knockout on both sides of the channel

± The units listed here are black as standard. ACO Monoblock PD100D is also available in grey and natural buff. For further information please contact our Customer Support Team 01462 816666.

Note. For information on channel and access unit functionality see page 18. Access units supplied with ductile iron lockable covers.



ACO MultiDrain™ Monoblock PD100D

Sump unit

Product code	Description	Length (mm)	Width overall (mm)	Depth overall (mm)	Invert depth (mm)	Slot width	Invert Type	Weight (kg)
20900	PD100D No. 900 universal sump unit with plastic silt bucket	500	150	668	642	8	-	42.8

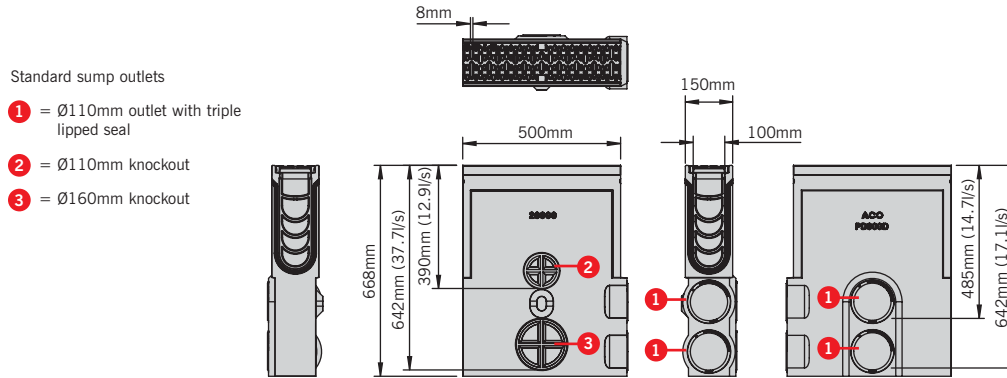

Note. Drawing shows flow through un-trapped unions. For information on sump unit functionality see page 20. Sump supplied with ductile iron lockable grating.

Sump unit accessories

Product code	Description	Length (mm)	Width overall (mm)	Depth overall (mm)	Weight (kg)
23415	Drainlock™ security locking assembly	-	-	-	0.1
23416	Drainlock™ security key	-	-	-	0.01
1367	Drainlock™ grating lifting tool 835	-	-	-	0.1



Drainlock™ security lock assembly



Drainlock™ security lock key



Drainlock™ security lock lifting tool

ACO MultiDrain™ Monoblock PD100D

Drain unions and foul air traps

Product code	Description	Length (mm)	Width overall (mm)	Depth overall (mm)	Invert depth (mm)	Slot width	Invert Type	Weight (kg)
0056	820 Drain union PVC-U Ø110mm	100	110	-	-	-	-	0.1
0058	822 Drain union PVC-U Ø160mm	100	160	-	-	-	-	0.5
2640	920 Foul air trap PVC-U Ø110mm	-	110	-	-	-	-	0.5
2638	922 Foul air trap PVC-U Ø160mm	-	160	-	-	-	-	1.9
7931	940 Roddable foul air trap MDPE Ø110mm	-	110	-	-	-	-	0.6
7932	950 Roddable foul air trap MDPE Ø160mm	-	160	-	-	-	-	0.8

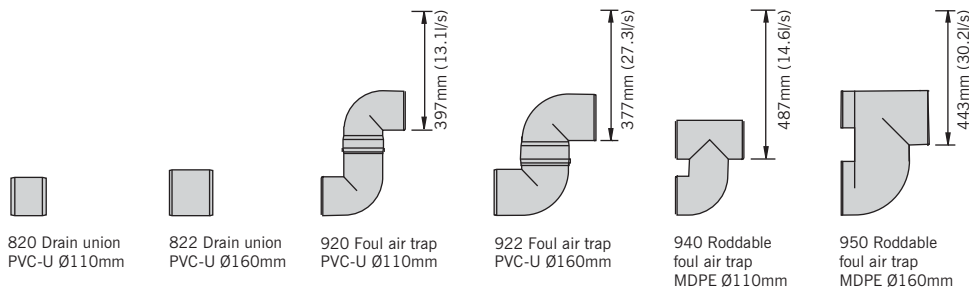

Note. For information on drain union and foul air trap functionality see pages 18 and 21.

Universal gully and components

Product code	Description	Length (mm)	Width overall (mm)	Depth overall (mm)	Invert depth (mm)	Slot width (mm)	Invert Type	Weight (kg)
33401	Gully assembly and bucket 601D	440	440	1315	870	10	-	52.5
33402	Gully assembly no bucket 602D	440	440	1315	870	10	-	51.0
33407	Gully top assembly 607D	440	440	655	-	10	-	45.0
33605	Gully base unit 605	-	Ø375	750	310	-	-	4.3
33603	Gully intermediate unit 603	440	440	515	-	-	-	5.1
44355	Gully grating and frame 600D	400*	564††	100	-	10	-	40.0
7060	Gully connector 615	500	Ø500	40	-	-	-	7.0
33606	Bucket polyethylene 606	-	Ø275	245	-	-	-	1.4

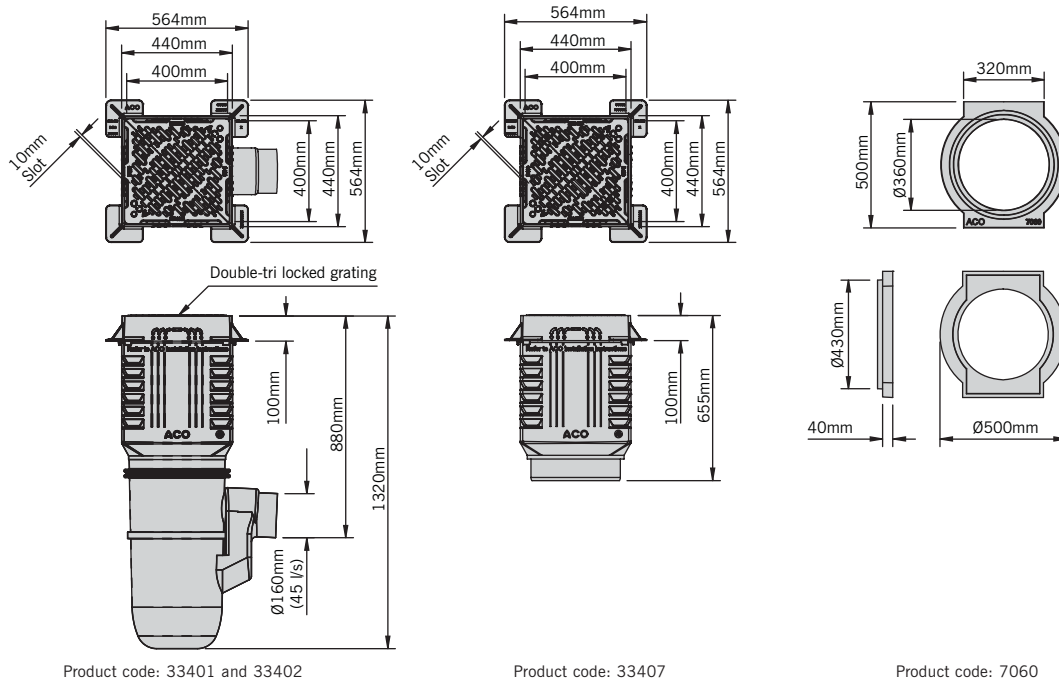

Product code: 33401 and 33402

Product code: 33407

Product code: 7060

Note. Plain U-PVC 150mm - 160mm Supersleeve adaptor supplied with 601D, 602D and 605 assemblies. For information on universal gully functionality see page 21. *Clear opening size. ††Over frame size.



Designing an ACO MultiDrain™ Monoblock PD100D drainage system

ACO Hydraulic Design Software is designed to aid engineers in selecting the appropriate channel to suit the area to be drained. This free online tool calculates the hydraulic capacity of channels accepting flow along their entire length using differential equations for spatially varied flow. The software accurately analyses the selected channel to check it has suitable capacity. Furthermore it can optimise the selection and potentially downsize all or part of a channel run if it is oversized.

Designing a drainage system

The total drainage catchment for each section of the run is required for input; this is combined with the rainfall to generate the inflow into the channel.

When designing a channel drainage system, 50mm/hr will generally comply with the requirements stated in the guidance to the Building Regulations (Part H 2002).

Where the project must comply with the National Standards for Sustainable Drainage Systems, multiple rainfall events using design rainfall specific to the geographical location of the site must be analysed. The rainfall data is normally sourced from the Flood Studies Report (in some circumstances designs may also need to be checked using rainfall from the Flood Estimation Handbook).

Depending upon the application and lifespan of the system, a return period and storm duration should be selected e.g. 1:30 year or 1:100 year return period (potentially plus climate change).



It should be noted that other calculation methods will not give the correct results for channel drainage systems. In particular the use of equations of steady uniform flow, such as Manning's equation, is not appropriate for channel drainage design. They will not work with level channels and give grossly inaccurate results at shallow gradients.

Where the attenuation volume of the large capacity channels is to be analysed, the storage requirements will need to be determined for a range of different storms.

ACO can provide channel data for use in proprietary software, such as Micro Drainage. Please contact the ACO Water Management Design Services Team.

ACO Water Management Design Services Team

ACO has embraced the concept of value engineering as an approach to on-site construction that saves both time and money. ACO will review any design to minimise the total scheme and life cost of a proposal. By using ACO Monoblock water can be contained and conveyed close to the surface conforming to the National Standards of Sustainable Drainage Systems.

For detailed designs using the ACO Hydraulic Design Software, please contact the ACO Water Management Design Services Team. The team should also be consulted for advice where the inflow is not uniformly distributed along the channel.

The hydraulic performance tables within the relevant sections have been produced from the ACO Hydraulic Design Software to facilitate a quick manual design method for the determination of the drainage requirements.

ACO Water Management Design Services Team

Tel: 01462 816666
Email: technical@aco.co.uk



ACO Hydraulic Design Software

Discover how our free design software allows you to create more effective hydraulic plans.

- ▶ All designs are securely stored and easily accessed online
- ▶ Data always up-to-date
- ▶ Proven calculation methodology - more accurate and efficient designs
- ▶ Flexible catchment design
- ▶ Integrated rainfall data
- ▶ Automated product optimisation
- ▶ PDF summary documents



Register Now - It's Free
www.acodesign.co.uk



Design example

For a design of ACO Monoblock PD100D, assume the following figures:

$D = 34\text{m}$ (depth of catchment area)

$L = 45\text{m}$ (length of channel run = length of catchment)

$i = 50\text{mm/h}$ (design rainfall intensity)

Ground slope = 0%

Note that any other rainfall intensity may be used. Typical intensities (from BS EN 752) are 50mm/h for areas where some ponding could be tolerated for a few minutes after heavy rainfall, or 75mm/h where ponding cannot normally be tolerated.

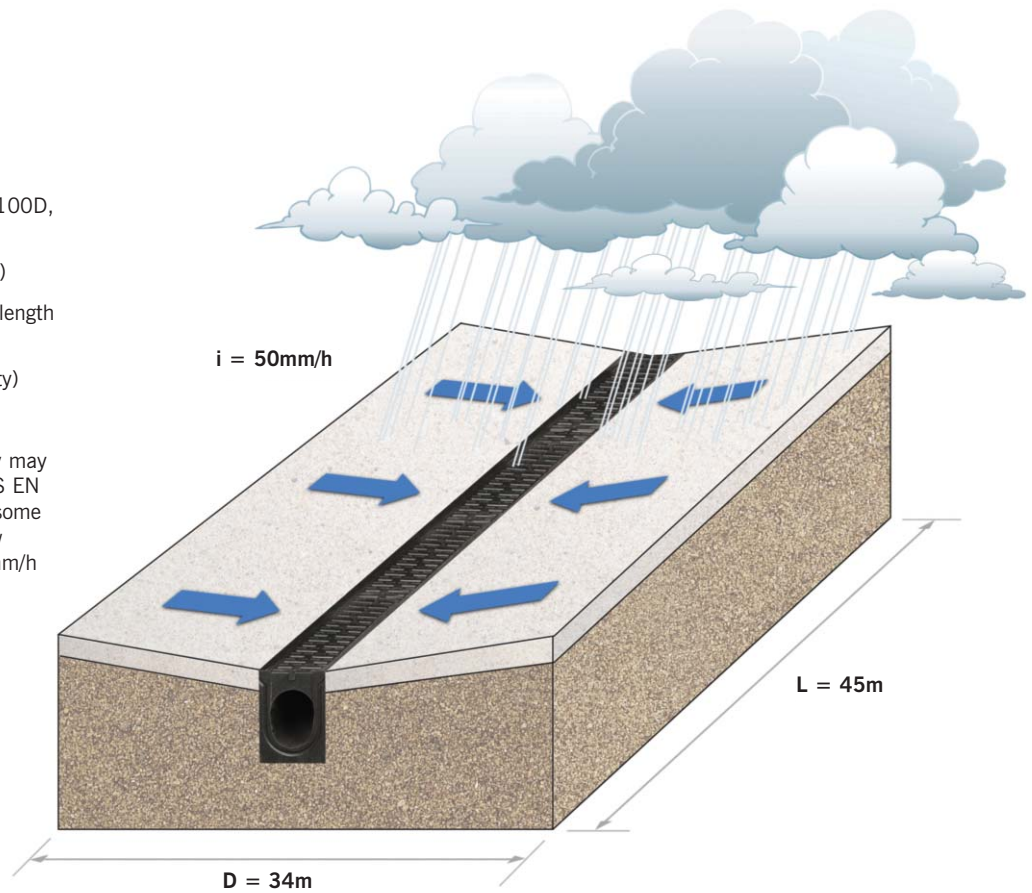

GUIDANCE NOTES

1. Determine the area

$$\text{Area} = L \times D = 45 \times 34 = 1530\text{m}^2$$

For a quick analysis, see the tables and the columns for Area.

1530m² is too large for one 45m run of ACO Monoblock PD100D

$$\text{Try } 1530\text{m}^2 \times 1/2 = 765\text{m}^2$$

$$L \times 1/2 = 22.5\text{m}$$

Estimating between the rows for 20m and 30m lengths.

One 22.5m run of ACO Monoblock PD100D 20.1 can drain approx 880m². Hence two runs can drain the 1530m².

Or for a more detailed analysis, determine the total flow rate, as follows:

2. Determine total flow (Q)

$$Q = (\text{Area} \times i) / 3600 = (1530 \times 50) / 3600 = 21.3 \text{ l/s}$$

3. Determine lateral inflow (q)

$$q = Q / L = 21.3 / 45 = 0.473 \text{ l/s/m}$$

4. Determine suitable channel sizes and lengths

For example, would a sump at 1/3 length work with a lateral inflow of 0.473 l/s/m?

1/3 L = 15m, ACO Monoblock PD100D 10.1 will be adequate

2/3 L = 30m, ACO Monoblock PD100D 30.1 will be adequate

5. Check outlet capacity

Check the capacity for each proposed outlet by referencing the product parts tables in this brochure.

Option 1

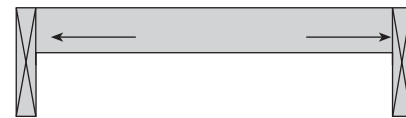

Option 2

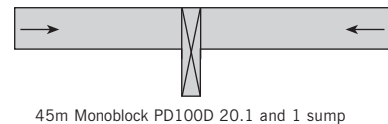

Option 3

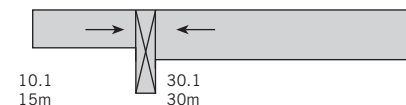

15m Monoblock PD100D 10.1, 30m Monoblock 30.1 and 1 sump

X Denotes sump unit

ACO MultiDrain™ Monoblock PD100D hydraulic performance tables

Hydraulic capacities

The tables opposite shows the maximum capacity of the unit, assuming uniform lateral inflow. The capacity will depend on the length of the unit to the outlet and on any slope along the unit.

Q (l/s) is the maximum total flow that the channel can carry.

q (l/s/m) is the maximum possible lateral inflow.

A (m²) is the maximum area that can be drained and will depend on the design rainfall intensity chosen.

The tabulated areas are for a rainfall of 50mm/hr (0.014 l/s/m²) and will generally comply with the requirements stated in guidance to The Building Regulations (Part H 2002). Where the project must comply with the National Standards for Sustainable Drainage Systems, multiple rainfall events using design rainfall specific to the geographical location of the site must be analysed. The ACO Water Management Design Services Team will be able to assist with this process.

At other rainfall intensities, the area can be determined by proportion, e.g. at 75mm/hr, the maximum area drained will be the tabulated area x 50/75.

ACO Water Management Design Services Team

Please contact the ACO Water Management Design Services Team on 01462 816666 for advice on channels with non-uniform inflow, or channels receiving point inflows at the end or at intermediate locations. The ACO Water Management Design Services Team will be pleased to assist with any technical queries, scheme designs or parts schedules.

Designing a drainage system

An example design method is provided on page 14 to help determine your drainage requirements.

This example will enable you to use the hydraulic performance tables on these pages.

ACO PD100D 0.1 constant depth channel									
Length to outlet (m)	Slope %								
	0%			0.5%			1%		
	Q (l/s)	q (l/s/m)	A (m ²)	Q (l/s)	q (l/s/m)	A (m ²)	Q (l/s)	q (l/s/m)	A (m ²)
10	5.30	0.530	381.60	7.50	0.750	540.00	8.90	0.890	640.80
20	4.80	0.240	345.60	8.00	0.400	576.00	10.00	0.500	720.00
30	4.50	0.150	324.00	8.40	0.280	604.80	10.50	0.350	756.00
40	4.40	0.110	316.80	8.60	0.215	619.20	11.00	0.275	792.00
50	4.00	0.080	288.00	8.75	0.175	630.00	11.50	0.230	828.00
60	3.90	0.065	280.80	8.82	0.147	635.04	11.55	0.193	831.60
70	3.78	0.054	272.16	8.89	0.127	640.08	11.69	0.167	841.68
80	3.60	0.045	259.20	8.96	0.112	645.12	11.76	0.147	846.72
90	3.42	0.038	246.24	9.00	0.100	648.00	11.97	0.133	861.84
100	3.30	0.033	237.60	9.12	0.091	656.64	12.00	0.120	864.00

ACO PD100D 10.1 constant depth channel									
Length to outlet (m)	Slope %								
	0%			0.5%			1%		
	Q (l/s)	q (l/s/m)	A (m ²)	Q (l/s)	q (l/s/m)	A (m ²)	Q (l/s)	q (l/s/m)	A (m ²)
10	9.20	0.920	662.40	11.90	1.190	856.80	13.80	1.380	993.60
20	8.40	0.420	604.80	12.60	0.630	907.20	15.40	0.770	1108.80
30	7.95	0.265	572.40	12.90	0.430	928.80	16.20	0.540	1166.40
40	7.44	0.186	535.68	13.20	0.330	950.40	16.80	0.420	1209.60
50	7.10	0.142	511.20	13.50	0.270	972.00	17.15	0.343	1234.80
60	6.72	0.112	483.84	13.62	0.227	980.64	17.40	0.290	1252.80
70	6.51	0.093	468.72	13.65	0.195	982.80	17.64	0.252	1270.08
80	6.32	0.079	455.04	13.76	0.172	990.72	17.84	0.223	1284.48
90	6.12	0.068	440.64	13.86	0.154	997.92	17.91	0.199	1289.52
100	5.90	0.059	424.80	13.90	0.139	1000.80	18.00	0.180	1296.00

ACO PD100D 20.1 constant depth channel									
Length to outlet (m)	Slope %								
	0%			0.5%			1%		
	Q (l/s)	q (l/s/m)	A (m ²)	Q (l/s)	q (l/s/m)	A (m ²)	Q (l/s)	q (l/s/m)	A (m ²)
10	13.55	1.355	975.60	17.00	1.700	1224.00	19.30	1.930	1389.60
20	12.46	0.623	897.12	17.80	0.890	1281.60	21.00	1.050	1512.00
30	11.70	0.390	842.40	18.30	0.610	1317.60	22.20	0.740	1598.40
40	11.20	0.280	806.40	18.40	0.460	1324.80	22.80	0.570	1641.60
50	10.55	0.211	759.60	18.55	0.371	1335.60	23.50	0.470	1692.00
60	10.20	0.170	734.40	18.66	0.311	1343.52	23.70	0.395	1706.40
70	9.80	0.140	705.60	18.76	0.268	1350.72	23.80	0.340	1713.60
80	9.44	0.118	679.68	18.80	0.235	1353.60	24.00	0.300	1728.00
90	9.00	0.100	648.00	18.81	0.209	1354.32	24.30	0.270	1749.60
100	8.80	0.088	633.60	18.90	0.189	1360.80	24.50	0.245	1764.00



ACO PD100D 30.1 constant depth channel									
Length to outlet (m)	Slope %								
	0%			0.5%			1%		
	Q (l/s)	q (l/s/m)	A (m ²)	Q (l/s)	q (l/s/m)	A (m ²)	Q (l/s)	q (l/s/m)	A (m ²)
10	18.70	1.870	1346.40	22.00	2.200	1584.00	25.50	2.550	1836.00
20	17.20	0.860	1238.40	23.00	1.150	1656.00	27.20	1.360	1958.40
30	16.20	0.540	1166.40	23.70	0.790	1706.40	28.50	0.950	2052.00
40	15.20	0.380	1094.40	24.00	0.600	1728.00	29.20	0.730	2102.40
50	14.50	0.290	1044.00	24.50	0.490	1764.00	30.00	0.600	2160.00
60	13.80	0.230	993.60	24.60	0.410	1771.20	30.60	0.510	2203.20
70	13.30	0.190	957.60	24.70	0.353	1778.40	30.80	0.440	2217.60
80	12.80	0.160	921.60	24.72	0.309	1779.84	31.20	0.390	2246.40
90	12.60	0.140	907.20	24.75	0.275	1782.00	31.40	0.349	2260.80
100	12.00	0.120	864.00	24.80	0.248	1785.60	31.50	0.315	2268.00

ACO PD100D 0125 shallow depth channel									
Length to outlet (m)	Slope %								
	0%			0.5%			1%		
	Q (l/s)	q (l/s/m)	A (m ²)	Q (l/s)	q (l/s/m)	A (m ²)	Q (l/s)	q (l/s/m)	A (m ²)
10	1.28	0.128	92.16	2.15	0.215	154.80	2.65	0.265	190.80
20	1.12	0.056	80.64	2.30	0.115	165.60	2.98	0.149	214.56
30	1.02	0.034	73.44	2.40	0.080	172.80	3.12	0.104	224.64
40	0.96	0.024	69.12	2.44	0.061	175.68	3.20	0.080	230.40
50	0.88	0.018	63.36	2.45	0.049	176.40	3.30	0.066	237.60



Preparing the system for installation

This section provides guidance on the preparation steps that may be required for the installation of the ACO MultiDrain™ Monoblock PD100D system.

Access unit base pipe connection

All ACO Monoblock PD100D access units are supplied with a pre formed removable panel in the base for connection to Ø110mm PVC-U pipe.

Drill Ø8mm holes around the circular recessed groove in the base of the unit so the drilled holes almost touch each other. Support the channel on sand or soft earth and with a chisel work around the recessed groove removing any remaining material. Once all the holes have been connected, the central panel can be removed. Use a chisel to tidy up any remaining material.



Push fit pipe into recess provided and seal as required. For recommended sealants and sealing procedure refer to the section headed "watertight sealing".



Access unit side wall connection

Removable side panels are provided on both sides of the access units marked with a 'J' in the parts table. This allows channel runs to be connected together to form "T" or "L" junctions for continuous water flow through the system.

Use a disc cutter to cut along the central recessed guides through the full thickness of material. Ensure cuts extend to but not beyond the perimeter recess surrounding the removable panel.



Use a chisel to remove segments of the panel and tidy up any remaining material.



Channel connection can now be made and sealed as required. For recommended sealants and sealing procedure refer to the section headed "watertight sealing".



Access units hinged cover operation

All access units have a lockable hinged ductile iron cover to provide an entry point to the system for inspection and jetting. The orientation of the cover can be changed dependent on traffic direction. It is recommended the cover is orientated so that it opens against the traffic direction.

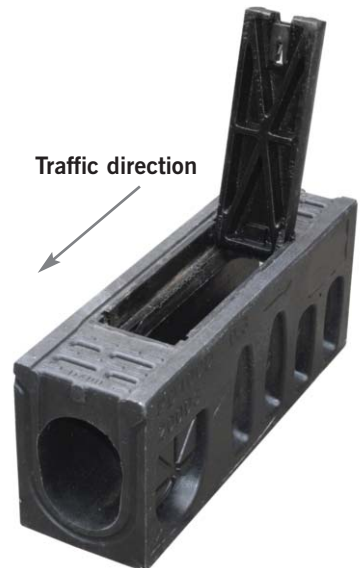

Using a large flat bladed screw driver insert in the position shown. Twist the screw driver 90° to slide and release the Powerlock fastening clip. The cover can now be opened by inserting a lifting tool through the hole in the Powerlock fastening clip and pulling upwards.



Hold the cover at about 45° and then lift vertically which will release the hinges from the ductile iron frame. The cover can then be rotated by 180° and inserted back into the hinge recesses provided. Check the cover opens and closes freely once fitted.



To lock the cover, insert tool and push to slide the clip into its locked position. The cover is now locked and ready for operation.

Fitting step connector

This unit is used between constant depth channel joints where a stepped fall installation is required. The step connector takes up a 50mm height difference only in channels and ensures a smooth water flow within the channel system.



Place the step connector into the base of the deeper channel to be jointed as shown. If a watertight installation is required, seal around the step connector. For recommended sealants and sealing procedure refer to the section headed "watertight sealing". Push channel joint together to lock the step connector in place forming a smooth transition between units.



Fitting caps

A single closing end cap is provided for all channel heights which can be cut down to size as required. This closing end cap can be fitted to either end of the ACO Monoblock channels.

Closing end cap cutting

To adjust the height of the closing end, ensure the top edge of the end cap is level with the top surface of the channel and mark the position. Precast cutting guides are provided. Use a disc cutter to cut the end cap. End cap can now be fitted and sealed as required ensuring the cap covers the entire jointing face of the channel*.



Inlet and Outlet end caps

Inlet and outlet end caps are provided and can be fitted to either end of the channels. Each unit is provided with a cast in Ø110mm PVC-U plain pipe spigot onto which pipe connections can be made. A suitable pipe lubricant will make pipe connection easier. End cap can now be fitted and sealed as required ensuring the cap covers the entire jointing face of the channel*.



*For recommended sealants and sealing procedure refer to the section headed "watertight sealing".

Preparing the system for installation - continued

Watertight sealing*

ACO Monoblock PD100D channels are generally installed without a water seal. Once butt jointed and with a concrete surround a fairly watertight installation is achieved. If however a watertight system is required each ACO Monoblock PD100D channel is provided with a sealant groove allowing the system to be sealed by the application of a flexible sealant during installation. For rainwater applications we recommend a single component polyurethane based elastomeric joint sealant such as BASF Masterflex 472 or Sika Sikaflex 11FC or similar. Application of the sealant to be in accordance with the sealant manufacturer's recommendations but, for guidance only, a typical method of application is as follows.

Jointing faces of the channels must be sound and clean. Remove all loose material, dust, oil and grease. This can be done by the use of a wire brush. Ensure jointing faces remain clean at all times (surfaces can be damp but no water droplets should be evident).



Apply sealant with a cartridge gun in a 10mm continuous bead following the groove provided on the end face of the channel to be sealed. Sealant should stand 5mm proud of the channel end face so that it will be compressed when the joint is closed.



Install the next cleaned channel by pushing the joint closed horizontally so as not to smear the sealant bead. Close the channel joint so there is no more than a 1mm gap between channels. Wipe away any excess sealant and leave to cure before use as per the sealant manufacturer's recommendations. Repeat steps as required.



Connecting the sump unit

A polymer concrete sump unit is provided for all channel heights in the ACO Monoblock range. It provides the capacity to hold silt and debris and multiple pipe connections to outlet to on-going pipework.



For pipe connections, remove the plastic Ø110mm caps. Ensure seals are clean and free of debris before connecting pipework. A suitable pipe lubricant will make pipe connection easier.

*ACO Monoblock PD100D channels are tested to confirm compliance with the watertightness requirements of BS EN 1433 when filled with water to the top of the channel bore. See the watertightness note on page 23 for more information.

Channel connection details can be removed using a disc cutter and chisel at the appropriate channel height. Cutting guide recessed grooves are provided and should be followed taking care not to cut beyond the areas to be removed.



Channel connection can now be made and sealed as required. For recommended sealants and sealing procedure refer to the section headed "watertight sealing"

Two removable panels are provided for Ø110mm and Ø160mm PVC-U pipe connections in the positions shown. For panel removal follow the same method described in "Access unit base pipe connection" on page 12.

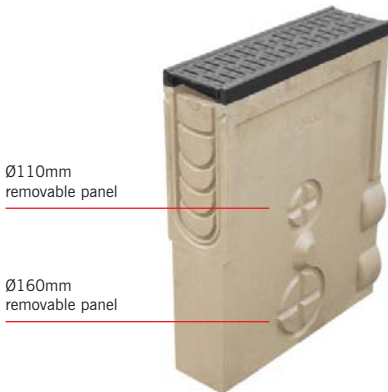

Ø110mm removable panel

Ø160mm removable panel

Connecting roddable foul air traps

A drain connector available in Ø110mm and Ø160mm for connection to foul or combined drainage is available.



Ø160mm foul air trap



Ø110mm foul air trap

Foul air traps come complete with a removable bung for rodding and are manufactured from highly durable recyclable MDPE.



Connecting the ACO Universal Gully

The ACO Universal Gully is a modular system designed for use with all channel heights within the ACO Monoblock PD100D channel system. The Universal Gully is provided with a lockable load class D 400 grating with Heelguard™ slots. The gully base provides silt retention and management for the channel system and outlet pipe connection to the on-going drainage network.

Once installed, the ACO Universal Gully can be cut to match channel depth as shown using a pad saw or similar. Use the shape of connecting channel bore as a cutting guide. Channel connection can now be made and sealed as required. For recommended sealants and sealing procedure refer to the section headed "watertight sealing".

Ductile cast iron hinged cover



Cutting guide to suit most ACO channels



Silt bucket



Gully base including roddable foul air trap

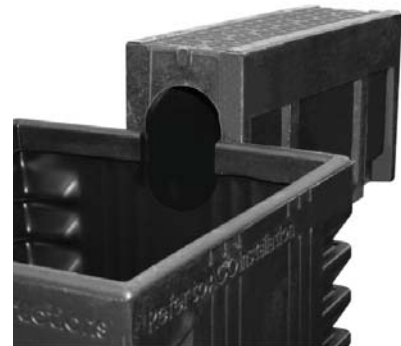

Installation detail

ACO MULTIDRAIN MONOBLOCK PD100D

Asphalt pavement

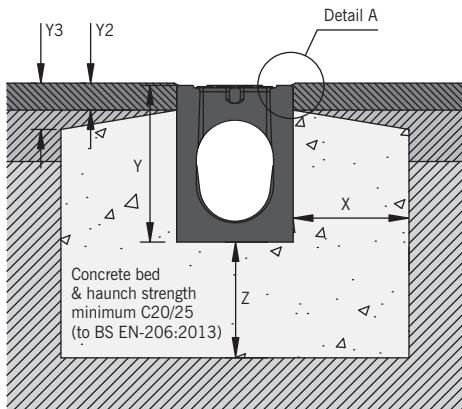

Concrete pavement

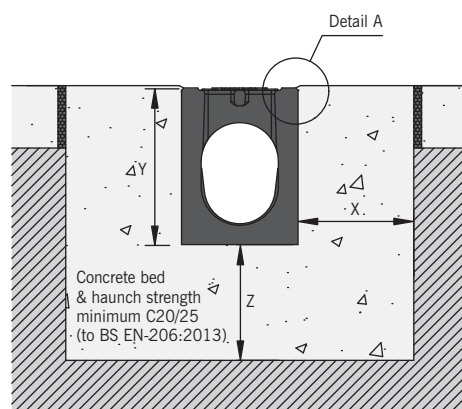

1.0 Load Class

Installation recommendations shown are ACO minimum recommendations for BS EN 1433:2002 load class requirements.

2.0 Ground Conditions

The long term performance of a channel installation to sustain vertical and lateral loads depends upon A) ground conditions B) stability of the adjacent pavement and C) a durable concrete bed and surround. The recommended installation detail may require the minimum dimensions to be revised to achieve site specific load class requirements (referred to in 1.0 above).

3.0 Cutting and Jointing

Mitre joints are formed by cutting the channels to the required angle and butting them together with appropriate sealant (e.g. Sikaflex 11FC or similar) or ACO Repair Kit. Where possible 90° joints and T's should be formed so that gratings do not have to be cut. Angles can be formed by connecting them using proprietary PVCu pipework attached to ACO inlet/outlet endcaps. For further details please contact ACO Design Services Team.

Note: For Load Classes higher than C 250, mitred joints are not recommended in vehicular areas. Where requested ACO can custom manufacture angled junctions to order.

4.0 Isolation Joints

The channel must be isolated from the surrounding environment. An isolation joint must be positioned up to 1500mm from the channel wall. Any dowel bars must be located no nearer than 150mm from the channel wall. Other isolation joints in surrounding slab must be continued through the channel.

Additional crack control may be required to comply with specifier requirements.

5.0 Installation into in-situ Slab

Where a channel is to be installed into an existing concrete slab it is necessary to cut a suitably sized pocket in the slab. The channel will then need to be bedded in polymer modified mortar of 25mm minimum thickness (this may vary depending on the type of mortar used). Engineering advice may be necessary.

6.0 Temporary Installation

A channel installation is not complete until the final surfacing is laid. In any temporary condition, i.e. with the channel walls projecting above adjacent ground, site traffic should not cross channels. Loose boards, stone fill or cover plates will not protect the channel walls or grating. A temporary channel crossing should be formed by raising the ground level locally, to 3 - 6mm above top of edge rail, either side of a channel for a distance of 750 to 1000mm, to form ramps. Note that the channel load class should be adequate to carry the site traffic.

7.0 Block Pavements

The channel must be supported laterally. Blocks laid directly against a channel must be laid as a soldier course and restrained from movement by bedding securely on the concrete haunch e.g. by using a polymer modified mortar for bed and perpendicular joints (e.g. RONAFIX mortar mix C or similar). Blocks or slabs bedded on sand remote from the channel should be set at a higher level to compensate for possible settlement of the paving in service.

Block pavement options 1 and 2

Detail A

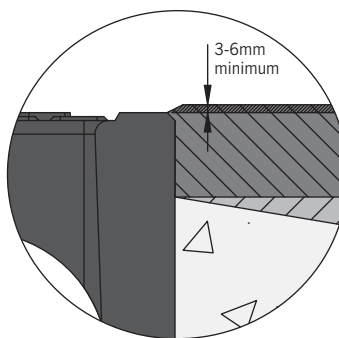
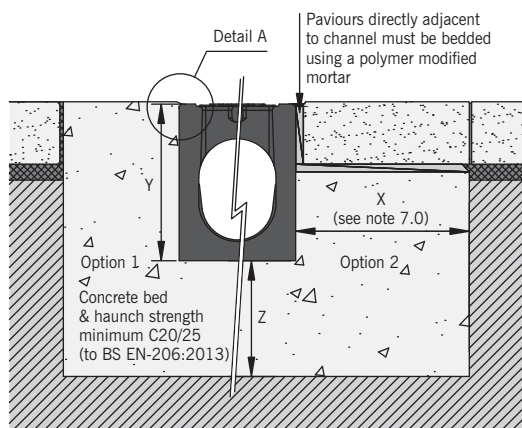

8.0 Access Unit Locking System

Ductile iron access unit cover should be securely fixed and the clip slid into the locked position.

9.0 Channel Protection

Avoid contact between compaction equipment and top of ACO channel edge rail. The installer must ensure that the finished surface level lies above the top of the edge rail (by at least 3-6mm). Covering or protecting the grating, before concreting the haunch or laying blocks, removes the time and cost associated with cleaning the channel and grating of cement material and embedded stones.

10.0 Watertight Installation to BS EN 1433:2002

Where ACO channel joints/fittings and channel/pavement interfaces are to be sealed, an appropriate sealant should be used (e.g. Sikaflex 11FC or similar). Guidance on the necessary surface preparation and/or priming should be sought from the sealant manufacturer.



These details are available to download in DWG or PDF format from the ACO website. Please go to www.aco.co.uk and sign in or register to access this information.

Best practice and workmanship

ACO can give guidance with respect to the most suitable methods of installation for each of the products in the ACO MultiDrain™ Monoblock PD100D range. ACO MultiDrain™ Monoblock PD100D should be installed using acceptable levels of workmanship and according to the National Code of Practice (UK: BS8000: Part 14: 1989) in keeping with EN 1433:2002 (Drainage channels for vehicular and pedestrian areas).

Detailed installation statements and methodologies will vary for all sites as each will have different aspects deserving particular consideration, consequently the relevant approvals should be sought from the consulting engineer and/or the installer.

For further information please contact our Design Services Team (technical@aco.co.uk) or the ACO website www.aco.co.uk.

11.0 Minimum Dimensions of Concrete Surround

Load Class		D400*
Minimum dimensions (mm)	X	150
	Y	Full channel height (Less Y ₂ where necessary)
	Z	150
Maximum Dimensions (mm)	Y ₁	35
	Y ₂	60

*E.g.. Parking areas for all types of road vehicle. Not suitable for carriageways of public roads or motorways.



Material benefits

The correct material selection for products installed in permanent works is extremely important to assure optimum performance throughout its design life.

ACO Monoblock PD100D is manufactured from Vienite®, ACO's sustainable high strength material. This material offers distinct advantages over other products and materials, addressing key specification and performance requirements for engineers and designers.



Sustainable use of materials

Efficient use of material resources is a key contributor to sustainability in construction. ACO Monoblock PD100D has been carefully designed to maximise strength while minimising material use.

- Vienite® combines the mechanical and performance benefits of synthetic resin concrete with high levels of recycled fillers.
- Vienite® is a sustainable material that contains in excess of 20% by weight post consumer waste previously destined for landfill in the UK.

- Vienite® fully conforms to and exceeds all performance requirements as specified by BS EN 1433:2002 for channel drainage units.
- Vienite® is recyclable, i.e. it can be collected, processed and returned for re-use as a raw material.

The ACO Monoblock PD100D range also includes components manufactured from ductile iron which contain between 40% and 90% recycled material.

MECHANICAL PROPERTIES OF VIENITE®

The following data compares the advantages of Vienite® used to manufacture ACO Monoblock with Ordinary Portland Cement (OPC) concrete and recycled plastic composite materials.

Compressive strength

Vienite® has high compressive strength and is therefore extremely resistant to service loads.

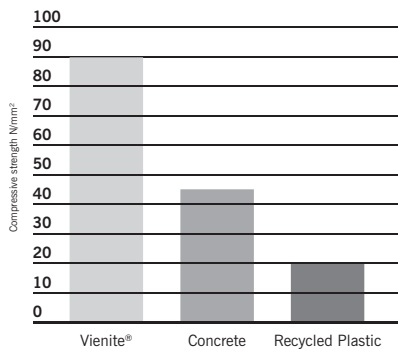

Flexural Strength

Vienite® has excellent flexural strength making the product resistant to side loads typically encountered during surfacing and installation.

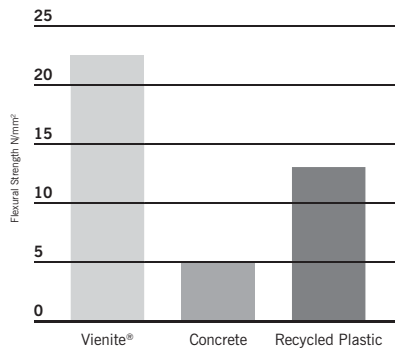

Coefficient of Thermal Expansion

Vienite® has a low coefficient of thermal expansion making it extremely stable, and unlike some materials it will not buckle or distort if subjected to high or low temperatures during service.

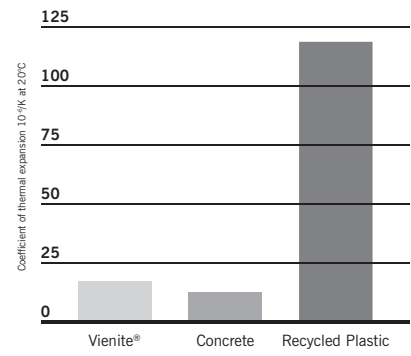

Water absorption

Vienite® has low water absorption of only 0.01% by weight which means surface water or liquids are contained within the product until discharge without contaminating surrounding soil or groundwater.

Coefficient of Friction (Mannings)

Vienite® is extremely smooth having a Mannings coefficient of 0.011 giving enhanced hydraulic performance and resisting the build up of silt and debris.

Chemical Resistance

Vienite® has high resistance to dilute acids and alkalis and is unaffected by road salts, fuels and oils which are typically encountered during service.

Chemical resistance chart

Vienite®, ACO's sustainable high strength material, has a high resistance to dilute acids and alkalis, and are unaffected by road salt, fuel and oil, and other commonly encountered chemicals.

Chemical medium	% conc	Resistance: Vienite®
Acetic acid, glacial	100	No
Acetic acid	10	Yes
Acetic anhydride	100	No
Acetone	10	No
Acetone	100	No
Alum	100	Yes
Aluminium sulphate	100	Yes
Ammonium chloride	100	Yes
Ammonium nitrate	100	Yes
Ammonium phosphate	65	Yes
Ammonium sulphate	100	Yes
Aniline (aminobenzene)	100	No
Barium chloride	100	Yes
Benzaldehyde	100	No
Benzene	100	No
Benzyl alcohol	100	Yes
Benzyl chloride	100	No
Borax	100	Yes
Boric acid	100	Yes
Bromine	100	No
Bromine water	Saturated	No
Butyl acetate	100	No
Butyric acid	100	Yes
Calcium carbonate	100	Yes
Calcium chloride	100	Yes
Calcium chlorate	8	Yes
Calcium hydroxide	100	Yes
Calcium nitrate	100	Yes
Carbon disulphide	100	No
Carbon tetrachloride	100	Yes
Castor oil	100	Yes
Chlorine gas, wet	100	No
Chlorine water	Saturated	No
Chlorobenzene	100	Yes
Chloroform (trichloro-methane)	100	No
Chromic acid	12	Yes
Citric acid	100	Yes
Copper chloride	100	Yes
Copper nitrate	100	Yes
Cyclohexane	100	Yes
Diesel fuel (DERV)	100	Yes
Dimethyl formamide	100	No
Dimethyl phthalate	100	Yes
Diethyl phthalate	100	Yes
Ethanol	95	No
Ethanolamine	100	Yes
Ethyl acetate	100	No
Ethylene glycol	100	Yes
Ferrous chloride	100	Yes
Ferric chloride	100	Yes
Ferrous sulphate	100	Yes
Formaldehyde	30	Yes
Formic acid	10	Yes
Formic acid	100	No
Fuel oil	100	Yes
Gasoline	100	Yes
Glycerine	100	Yes
Hydrazine	50	No

Chemical medium	% conc	Resistance: Vienite®
Hydrobromic acid	48	Yes
Hydrochloric acid	10	Yes
Hydrofluoric acid	10	No
Hydrogen peroxide	30	Yes
Lactic acid	100	Yes
Lead acetate	100	Yes
Magnesium chloride	100	Yes
Magnesium sulphate	100	Yes
Maleic acid	100	Yes
Methyl ethyl ketone (MEK)	100	No
Motor oil	100	Yes
Nickel chloride	100	Yes
Nickel sulphate	100	Yes
Nitric acid	5	No
Nitrobenzine	100	No
Oleic acid	100	Yes
Oxalic acid	100	Yes
Perchloric acid	10	Yes
Perchloroethylene	100	Yes
Phosphoric acid	20	Yes
Phosphorus trichloride	100	No
Potassium carbonate	50	Yes
Potassium chloride	100	Yes
Potassium dichromate	100	Yes
Potassium hydroxide	10	Yes
Potassium nitrate	100	Yes
Potassium permanganate	10	No
Potassium sulphate	100	Yes
Pyridine	100	No
Sodium acetate	100	Yes
Sodium bromide	100	Yes
Sodium carbonate	35	Yes
Sodium chlorate	100	Yes
Sodium chloride	100	Yes
Sodium hydroxide (caustic soda)	50	No
Sodium hypochlorite	18	No
Sodium nitrate	100	Yes
Sodium nitrite	100	Yes
Sodium phosphate	10	Yes
Sodium sulphate	100	Yes
Sodium sulphide	100	Yes
Sodium sulphite	100	Yes
Sodium thiosulphate	100	Yes
Stearic acid	100	Yes
Styrene	100	No
Sulphuric acid	75	No
Sulphuric acid	50	Yes
Sulphuric acid at up to 40°C	10	Yes
Tetachloroethylene	100	Yes
Thioglycolic acid	80	Yes
Thionyl chloride	100	No
Toluene	100	Yes
Toluene sulphonic acid (aqueous solution)	Saturated	Yes
Trichloroacetic acid	50	Yes
Turpentine	100	Yes
Water	100	Yes
Xylene	100	Yes
Zinc sulphate	100	Yes



Model specification clause

The channel drainage system shall be ACO Monoblock PD100D supplied by ACO Technologies plc. All materials and components within the scope of the system shall be supplied by this manufacturer. The channel units shall be fully compliant with BS EN 1433:2002 load class D 400 with Initial Type Test certification issued by a notified body independent of the manufacturer. The channel units are to be CE marked in accordance with the Construction Products Regulation with Declaration of Performance certification issued by the manufacturer.

All units shall be one piece manufacture from Vienite® resin concrete with a minimum recycled content of 20% by weight. Water inlet design shall be Heelguard™ with 8mm wide slots.

The standard units shall be installed with the manufacturer’s components only as required for the scheme. The system shall be installed in accordance with the manufacturers printed recommendations, and works carried out as specified on drawings* and in accordance with recognised good practice. Standards of workmanship shall generally be as specified in BS EN 752 and BS 8000: Part 14:1989.

*Please insert relevant drawing number

NBS specification

ACO MultiDrain™ Monoblock PD100D should be specified in NBS Section Q10:180. Assistance in completing this clause can be found in ACO Technologies product entries in NBS Plus or a model specification can be downloaded from www.aco.co.uk. For further assistance, contact the ACO Water Management Design Services Team.

Conformity

The Monoblock PD100D system is CE marked in accordance with the Construction Products Regulation.

Declarations of Performance are available via the CPR Zone on our website, or on request. Please contact ACO Water Management Design Services Team on 01462 816666 for further assistance.

BS EN 1433:2002





ACO Technologies plc

- ACO Water Management
Civils + Infrastructure
Urban + Landscape
- ACO Building Drainage
- ACO Sport
- ACO Wildlife

ACO Water Management: Civils + Infrastructure

A division of ACO Technologies plc
ACO Business Park,
Hitchin Road,
Shefford,
Bedfordshire
SG17 5TE

Tel: 01462 816666

Fax: 01462 815895

e-mail Enquiries: awmenquiries@aco.co.uk

e-mail Sales: customersupport@aco.co.uk

e-mail Technical: technical@aco.co.uk

website: www.aco.co.uk

The ACO Group: A strong family you can depend on.

© July 2016 ACO Technologies plc. All reasonable care has been taken in compiling the information in this document. All recommendations and suggestions on the use of ACO products are made without guarantee since the conditions of use are beyond the control of the Company. It is the customer's responsibility to ensure that each product is fit for its intended purpose, and that the actual conditions of use are suitable. This brochure and any advice is provided by ACO Technologies plc (the Company) free of charge and accordingly on terms that no liability including liability for negligence will attach to the Company or its servants or agents arising out of or in connection with or in relation to this brochure or any such advice. Any goods supplied by the Company will be supplied solely upon its standard conditions of sale, copies of which are available on request. The Company's policy of continuous product development and improvement renders specifications liable to modification. Information provided in this brochure is therefore subject to change without prior notification.

ACO CARES ABOUT THE ENVIRONMENT

Printed on material approved by the Forest Stewardship Council (FSC) who provide a means of assuring that products come from responsibly managed forest.



ISO 9001
FM 13502



ISO 14001
EMS 538781



OHSAS 18001
OHS 524145